

TABLE OF CONTENTS

- 1. SAFETY & WARNINGS** 2
- 2. QUICK SPECS / MODELS** 2
- 3. TOOLS FOR INSTALLATION** 2
- 4. APPROVED LED LUMINAIRES** 2
- 5. ADDITIONAL TOUCHDIAL COMPONENTS** 2
- 6. INSTALLATION OVERVIEW** 2
 - 6.1 CONFIGURING YOUR TOUCHDIAL SYSTEM 2
 - 6.2 GENERAL SYSTEM DIAGRAM 3
 - 6.3 RECEIVER DIAGRAM - RGB(W) - HARDWIRED EXPANSION 3
 - 6.4 RECEIVER DIAGRAM - RGB(W) - WIRELESS EXPANSION 4
 - 6.5 RECEIVER DIAGRAM - 2-CH K-RANGE® 4
 - 6.6 RECEIVER DIAGRAM - SOLID COLOR DIMMING 4
- 7. INSTALLATION** 5
 - 7.1 TURN POWER OFF AT CIRCUIT BREAKER 5
 - 7.2 DETERMINE LOCATION TO INSTALL COMPONENTS 5
 - 7.3 WIRE DRIVER & LUMINAIRE TO RECEIVER(S) 5
 - 7.4 SET UP MASTER RECEIVER(S) 5
 - A. SET FUNCTION
 - B. WIRELESS EXPANSION
 - 7.5 SET UP SLAVE RECEIVER(S) 5
 - A. HARDWIRE EXPANSION
 - B. SET FUNCTION
 - 7.6 TURN POWER ON AT CIRCUIT BREAKER 6
 - 7.7 SYNC MASTER RECEIVER(S) TO TOUCHDIAL CONTROL(S) 6
- 8. TROUBLESHOOTING** 6
- 9. VOLTAGE DROP CHARTS** 7
- 10. ADDITIONAL RESOURCES** 7

1. SAFETY & WARNINGS

1. Install in accordance with national and local electrical code regulations.
2. This product is intended to be installed and serviced by a qualified, licensed electrician.
3. DO NOT connect directly to high voltage power. Install with a compatible Class 2 constant voltage LED driver (power supply).
4. Only install compatible 12V and 24VDC constant voltage luminaires.
5. This product is rated for indoor installation and is not protected against moisture.
6. Do not modify product beyond instructions or warranty will be void.

2. QUICK SPECS / MODELS

DI-RF-REC-CV-A

Input from Driver	Output to Load	Max Load
12 - 24VDC Constant Voltage	12 -24VDC Constant Voltage	4CH x 5A 4CH x 60W (12V) 4CH x 100W (24V) 4CH = 4 Channels

3. TOOLS FOR INSTALL

Mini flat-head
screwdriver

Wire Stripper

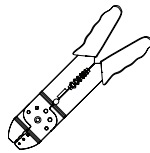
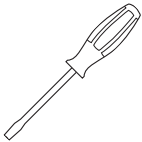

4. APPROVED LED LUMINAIRES

TOUCHDIAL is compatible with all Diode LED 12V and 24VDC constant voltage tape lights and fixtures.

5. ADDITIONAL TOUCHDIAL COMPONENTS



DI-RF-REM-RGBW-4
TOUCHDIAL RGB/RGBW Remote Control

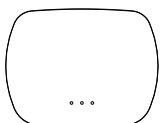

DI-WIFI-RF-TRMS
TOUCHDIAL WiFi Hub

6. INSTALLATION OVERVIEW

6.1 CONFIGURING YOUR TOUCHDIAL CONTROL SYSTEM

The following components are required to configure your TOUCHDIAL Control System:

a. LUMINAIRE

12-24VDC LED luminaire: Solid Color, K-Range, & RGB(W).

b. TOUCHDIAL RECEIVER

In each Zone, a minimum of 1 TOUCHDIAL receiver is set to MASTER and will communicate with Control via RF (Radio Frequency). See options 1. & 2. for expanding system:

1. Hardwired Expansion: Additional receivers are set to SLAVE and **wired** to MASTER receiver via DATA IN/OUT Terminals. An unlimited # of MASTER receivers can be paired to a single zone.

See *Diagrams 6.2 (Zone 1 & 2) and 6.3.*

- Allows for easy programming as only MASTER receiver is wirelessly paired with control. SLAVE receivers will automatically sync with MASTER receiver.
- This method is required for **syncing Dynamic Mode across receivers** for **RGB(W) installations**.
- This method is required to extend data signal beyond 95 ft.

2. Wireless Expansion: Additional receivers are set to MASTER and communicate with Control via RF. An unlimited amount of MASTER receivers can be paired to a single zone.

See *Diagrams 6.2 (Zone 2) and 6.4.*

- Each MASTER receiver will have to be individually paired to the control.
- This method is acceptable for Solid Color (Dimming) and 2CH K-RANGE installations.
- This method is acceptable for RGB(W) installations if syncing Dynamic Mode across receivers is not required.

c. Class 2 LED Driver

Used to power receiver and luminaire. Multiple receivers may be wired to a single driver (*do not overload driver*).

d. TOUCHDIAL Control

Minimum one control required:

- TOUCHDIAL RGBW Remote Control **and/or**
- TOUCHDIAL WiFi Hub & Apple/Android Mobile Device

6. INSTALLATION OVERVIEW

6.2 TOUCHDIAL GENERAL DIAGRAM

The diagram below shows an example of how to expand your TOUCHDIAL system hardwired or wirelessly. See RECEIVER DIAGRAMS for detailed connections to driver and luminaire.

Max RF Distance Control to MASTER Receiver: 95 ft.

Max # MASTER receivers paired to single zone: Unlimited

Max # Controls Paired to Each MASTER Receiver: Unlimited

Max Data Wire Distance: 300 ft.

Max Slaves Wired to MASTER Within 300 ft.: Unlimited

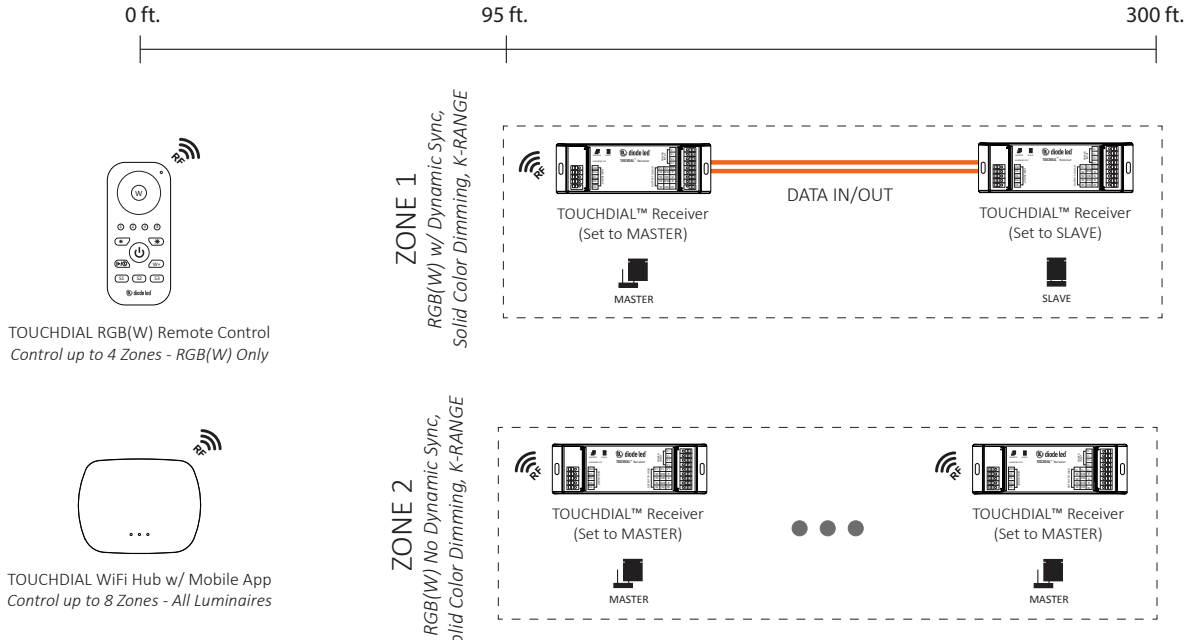

6.3 RECEIVER DIAGRAM - RGB(W) - HARDWIRED EXPANSION

Note: Required to sync Dynamic Mode across all receivers and extend data signal beyond 95 ft.

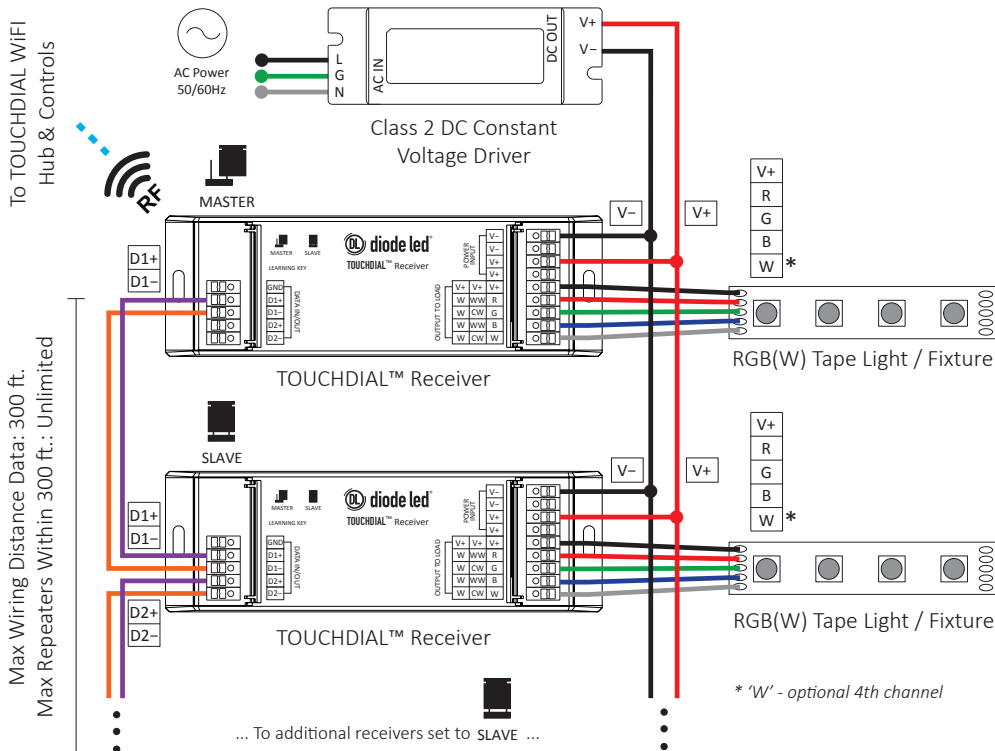

6. INSTALLATION OVERVIEW CONT.

6.4 RECEIVER DIAGRAM - RGB(W) - WIRELESS EXPANSION

Note: Dynamic Mode will not sync across all receivers

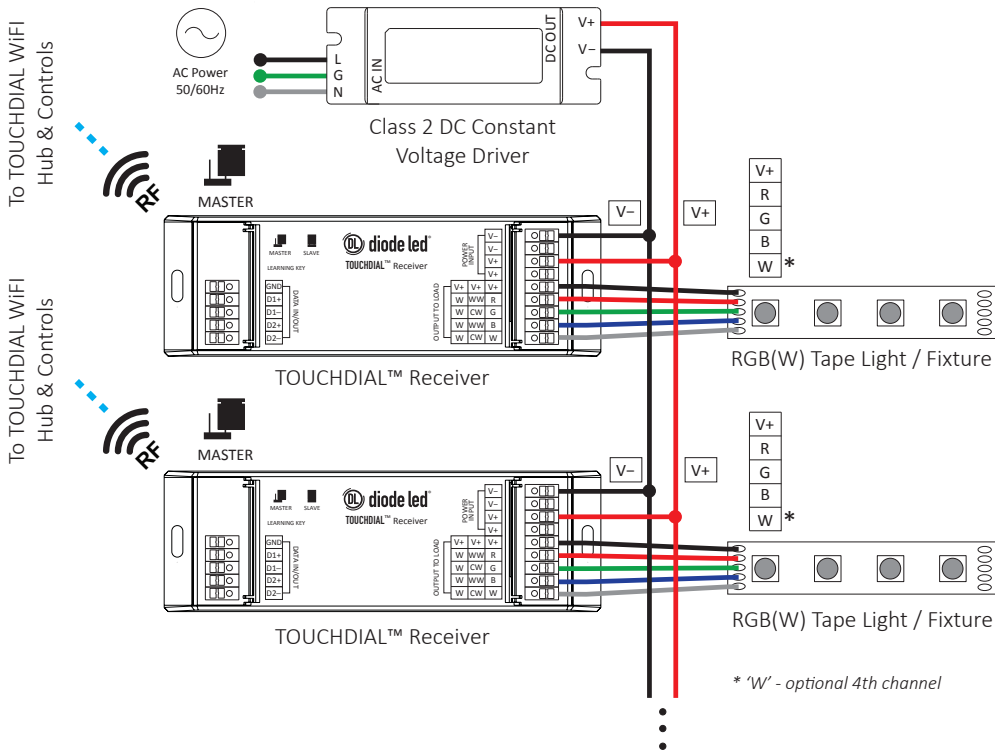

* 'W' - optional 4th channel

6.5 RECEIVER DIAGRAM - 2CH K-RANGE®

See RGB(W) Receiver Diagram for additional connections.

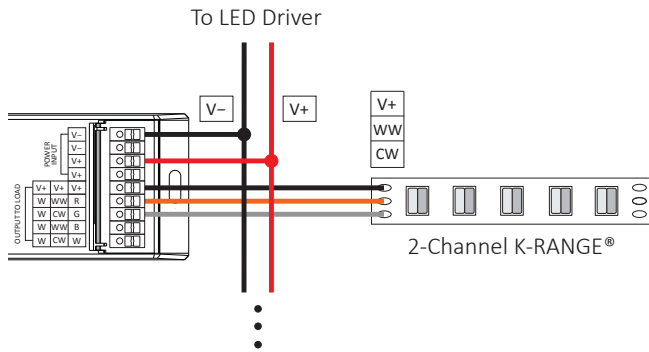

6.6 RECEIVER DIAGRAM - SOLID COLOR DIMMING

See RGB(W) Receiver Diagram for additional connections.

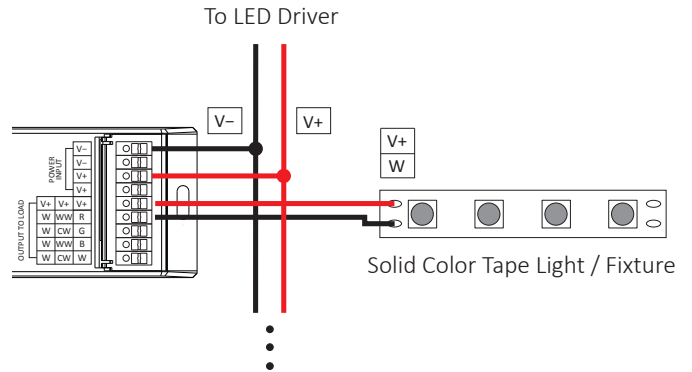

7. INSTALLATION

1 TURN POWER OFF AT CIRCUIT BREAKER



SHOCK HAZARD! May result in serious injury or death. Turn power OFF at circuit breaker prior to installation.

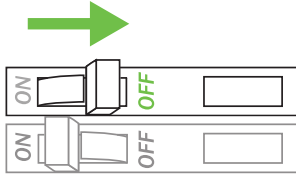

2 DETERMINE LOCATION TO INSTALL COMPONENTS

See 6. INSTALLATION OVERVIEW.

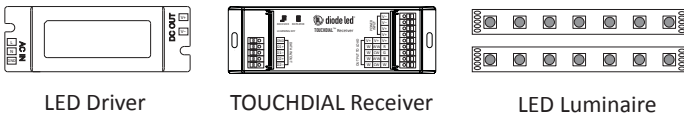

LED Driver

TOUCHDIAL Receiver

LED Luminaire

3 WIRE DRIVER & LUMINAIRE TO RECEIVER(S)

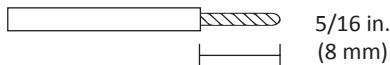

a. Strip wires.

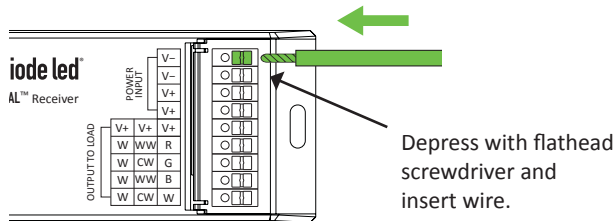

b. Wire Class 2 driver and LED luminaire to Receiver(s). See RECEIVER DIAGRAMS 6.3, 6.4, & 6.5.

VOLTAGE DROP

See VOLTAGE DROP CHARTS at end of this guide for wire gauge recommendations installed between driver and luminaire.

4 SET UP MASTER RECEIVER(S)

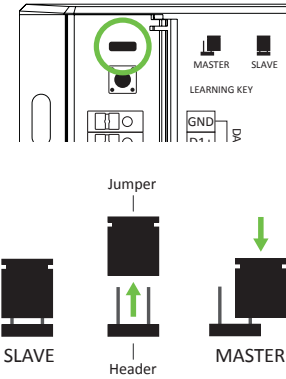

a. SET FUNCTION:

Set function of 1st Receiver in each Zone to MASTER. To do so, remove Jumper from Header and set back on single pin. This is now set as the MASTER receiver and will communicate with TOUCHDIAL controls via RF.

b. WIRELESS EXPANSION:

Set additional receivers to MASTER if DATA IN/OUT Terminals aren't required. Ensure to read **CONFIGURING A TOUCHDIAL SYSTEM - b. TOUCHDIAL RECEIVER** for additional information.

5 SET UP SLAVE RECEIVER(S)

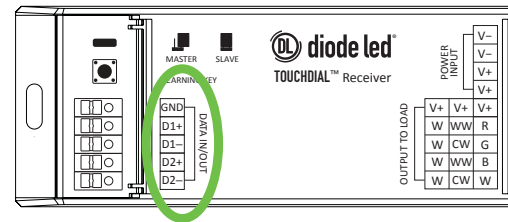

a. HARDWIRE EXPANSION:

It's required to hardwire SLAVE receivers to MASTER when Syncing Dynamic Mode for RGB(W) installations. Use CAT5 data cable or other thin gauge wire to link receivers together with DATA IN/OUT Terminals.



b. SET FUNCTION:

Set function of receivers hardwired to MASTER to SLAVE. SLAVE units will sync in real time with MASTER receiver.

MASTER/SLAVE NOTE

Power must be turned off when changing MASTER & SLAVE function. Otherwise, receivers won't respond to control correctly.

7. INSTALLATION CONT.

6 TURN POWER ON AT CIRCUIT BREAKER

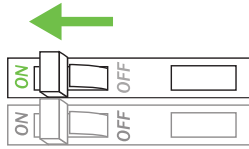

7 SYNC MASTER RECEIVER(S) TO TOUCHDIAL CONTROL(S)

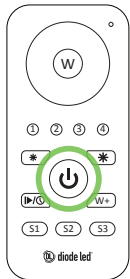

a. Wake up TOUCHDIAL control by pressing On/Off button.

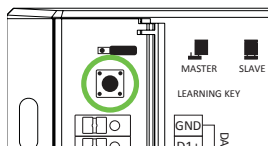

b. Press LEARNING KEY button on TOUCHDIAL MASTER receiver.



c. (1) Press any zone button on control, then (2) swipe finger on color wheel.

d. Luminaire will flash to indicate pairing.

The same syncing instructions apply when utilizing other TOUCHDIAL remote controls or mobile app. See TOUCHDIAL control installation guide (e.g. Remote or WiFi Hub) for more thorough pairing instructions.

HOW TO RESET TOUCHDIAL RECEIVER

If receiver is not operating or pairing correctly with control it may be necessary to turn power off/on and then reset the receiver. To reset, hold down the LEARNING KEY button for 5 seconds until LED flashes.

8. TROUBLESHOOTING

Prior to troubleshooting, turn power OFF at circuit breaker and verify all connections.

Symptom	Common Cause
Luminaire does not illuminate	<ul style="list-style-type: none"> • Incorrect wiring. • Polarity of Low Voltage V+ and V- are reversed. • Circuit breaker is OFF or tripped. • Incorrect voltage pairing of dimmer and luminaire. 12V drivers models will not power a luminaire with a higher voltage rating.
MASTER receiver does not sync with control	<ul style="list-style-type: none"> • Ensure function is set to MASTER (1 pin) - See step 4. • If still not syncing do following: 1) Turn off main power to receiver and turn back on. 2) Reset receiver by holding LEARNING KEY for 5 seconds until LED flashes. 3) Re-sync receiver to control.
Slave receiver does not sync with MASTER receiver	<ul style="list-style-type: none"> • Ensure function of MASTER receiver is set to 1 pin and SLAVE receiver is set to 2 pin - See steps 4 & 5. • Check D1+ and D1- connections. • If still not syncing do following: 1) Turn off main power to all receivers and turn back on. 2) Reset receivers by holding LEARNING KEY for 5 seconds until LED flashes. 3) Re-sync MASTER receiver to control. SLAVE receiver(s) will automatically sync with MASTER.
Luminaire heats up excessively	<ul style="list-style-type: none"> • Incorrect voltage pairing of driver and luminaire. Do not attach a 12V luminaire to a 24V driver. • Luminaire is not compatible. • Refer to luminaire install guide warnings and safety tips.

9. VOLTAGE DROP CHARTS

For best performance and lumen output, ensure proper wire gauge is installed to compensate for voltage drop of low voltage circuits.

Example: 12V Voltage Drop & Wire Length Distance Chart

Wire Gauge	10 W .83 A	20 W 1.7 A	30 W 2.5 A	40 W 3.3 A	50 W 2.1 A	60 W 4.2 A
18 AWG	34 ft.	17 ft.	11 ft.	8 ft.	6 ft.	5 ft.
16 AWG	54 ft.	27 ft.	18 ft.	13 ft.	10 ft.	9 ft.
14 AWG	86 ft.	43 ft.	29 ft.	21 ft.	17 ft.	14 ft.
12 AWG	134 ft.	68 ft.	45 ft.	34 ft.	27 ft.	22 ft.
10 AWG	199 ft.	99 ft.	66 ft.	49 ft.	39 ft.	33 ft.



1 Determine load size. Let's assume load is 55 W. Round up to nearest load.



2 Determine distance from driver to load. Let's assume the distance is 20 ft. Round up to nearest distance.



3 It's recommended to install 12 AWG to eliminate excess voltage drop.

12V Voltage Drop & Wire Length Distance Chart

Wire Gauge	10 W .83 A	20 W 1.7 A	30 W 2.5 A	40 W 3.3 A	50 W 2.1 A	60 W 4.2 A
18 AWG	34 ft.	17 ft.	11 ft.	8 ft.	6 ft.	5 ft.
16 AWG	54 ft.	27 ft.	18 ft.	13 ft.	10 ft.	9 ft.
14 AWG	86 ft.	43 ft.	29 ft.	21 ft.	17 ft.	14 ft.
12 AWG	134 ft.	68 ft.	45 ft.	34 ft.	27 ft.	22 ft.
10 AWG	199 ft.	99 ft.	66 ft.	49 ft.	39 ft.	33 ft.

24V Voltage Drop & Wire Length Distance Chart

Wire Gauge	10 W .42 A	20 W .83 A	30 W 1.3 A	40 W 1.7 A	50 W 2.1 A	60 W 2.5 A	70 W 2.9 A	80 W 3.3 A	100 W 4.2 A
18 AWG	134 ft.	68 ft.	45 ft.	33 ft.	27 ft.	22 ft.	19 ft.	17 ft.	14 ft.
16 AWG	215 ft.	109 ft.	72 ft.	54 ft.	43 ft.	36 ft.	31 ft.	27 ft.	22 ft.
14 AWG	345 ft.	174 ft.	115 ft.	86 ft.	69 ft.	57 ft.	49 ft.	43 ft.	36 ft.
12 AWG	539 ft.	272 ft.	181 ft.	135 ft.	108 ft.	90 ft.	77 ft.	68 ft.	56 ft.
10 AWG	784 ft.	397 ft.	263 ft.	197 ft.	158 ft.	131 ft.	112 ft.	98 ft.	82 ft.

10. ADDITIONAL RESOURCES

Visit the on-line product page at www.DiodeLED.com for additional product specifications & warranty information.

TOUCHDIAL RECEIVER SPECIFICATION SHEET

For full specifications.

TOUCHDIAL RGB/RGBW 4-ZONE REMOTE CONTROL SPECIFICATION SHEET & INSTALLATION GUIDE

For full specifications and installation instructions.

TOUCHDIAL WIFI HUB SPECIFICATION SHEET & INSTALLATION GUIDE

For full specifications and installation instructions.



Toll Free: 877.817.6028 | Fax: 415.592.1596 | www.DiodeLED.com | info@DiodeLED.com
© 2015 Elemental LED Inc. All rights reserved. Specifications are subject to change without notice.